

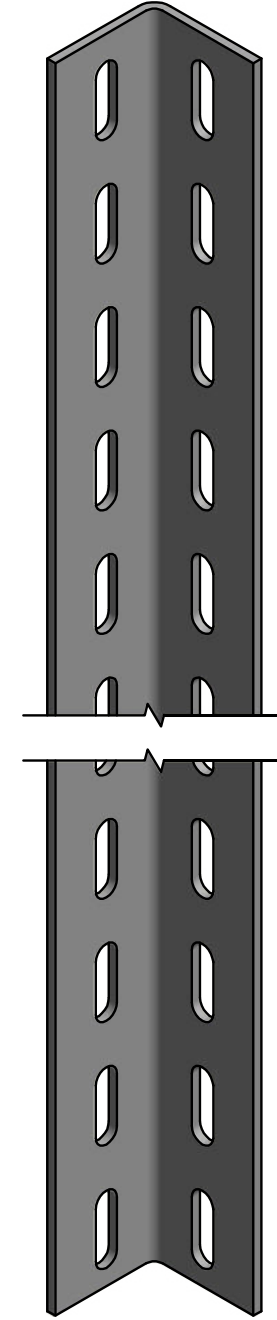

# ELNOVIS

**CABLES SUPPORT SYSTEMS  
TECHNICAL DATA SHEET**

PART NO	T	W	A	L	-
GE-LS-3	3	30	30	2000	
GE-LS-4	3	40	40	2000	

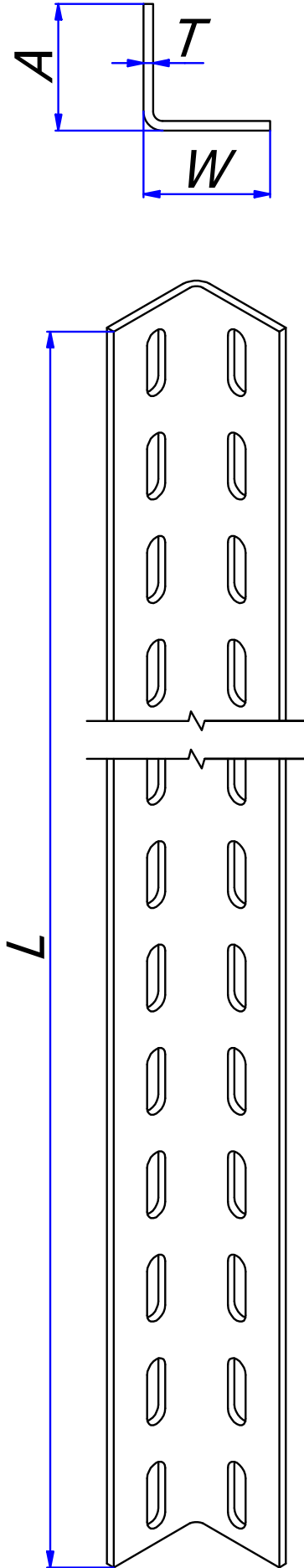

Değişiklik Revision	Tarih Date	Açıklama Explanation	GENEL İŞLEME TOLERANSLARI WORKING GENERAL TOLERANCES		GENEL PROFİL TOLERANSLARI PROFILE GENERAL TOLERANCES	
			Doğrusal / Linears	Açısal / Angulars	Yüzey / Finishing	Yüzey / Finishing
					✓ [✓]	✓ [✓]
MALZEME - Material			AĞIRLIK / Weight	KABA ÖLÇÜ-Rough Size	ADET - Quantity	VERİLMEYEN RADYÜSLER RADIUS NOT QUOTED :
ÇİZEN / Drawn by			K.DINLER			
KONTROL / Check.						
ONAY / Appr.						
ÖLÇEK / Scale			GRUP ADI - DESCRIPTION			DEĞ. YAPAN/Change by
			<b>L Channel, perforated</b>			TARİH / Date
						<b>GE-LS</b>

Dağıtım	İmza	Tarih	Kop.

Dağıtım	İmza	Tarih	Kop.

Dağıtım	İmza	Tarih	Kop.

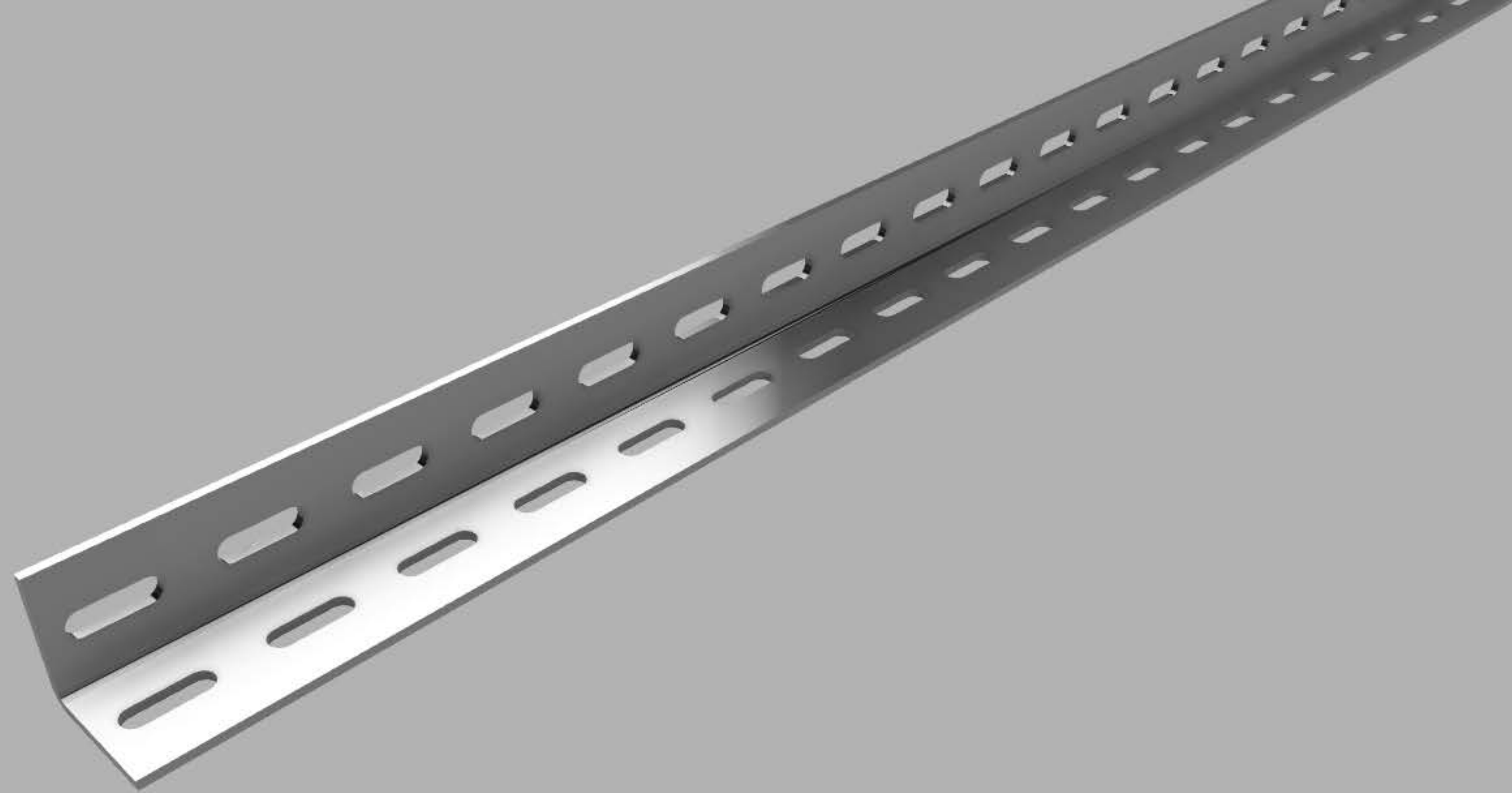

PART NO	T	W	L	-
GE-SL-30-3-2000	3	30	2000	
GE-SL-6-L2	4	40	2000	

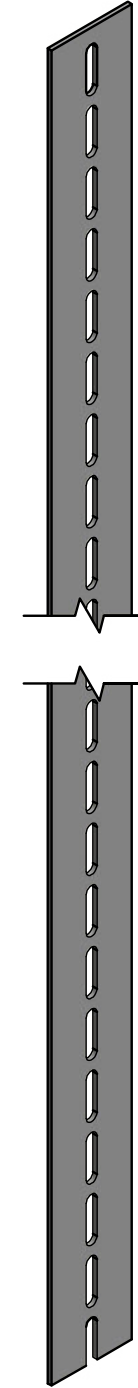
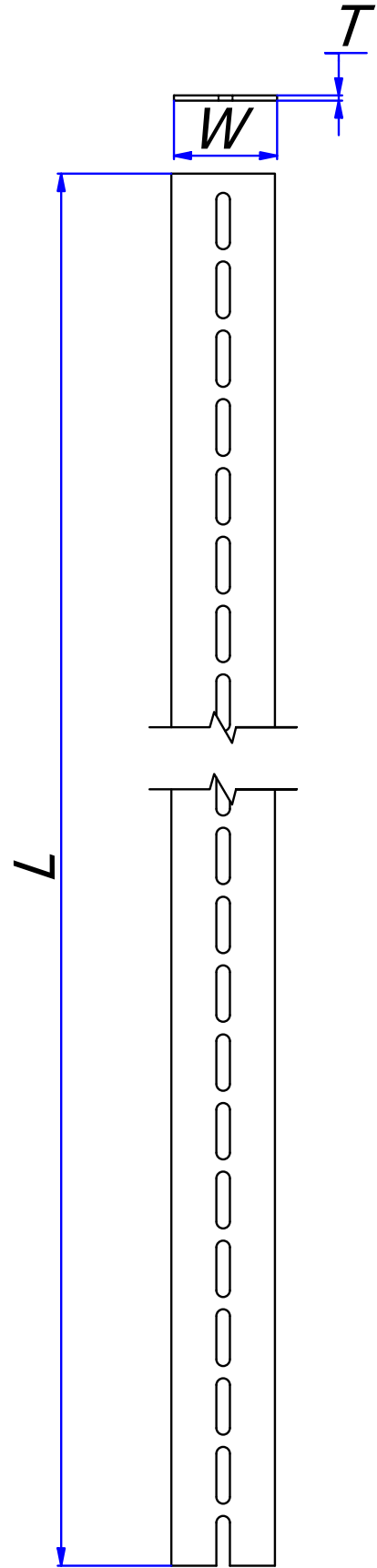

Dağıtım	Kop.
İmza	Tarih
İsim	
TEDARİK	

Dağıtım	Kop.
İmza	Tarih
İsim	
MALAT	

Dağıtım	Kop.
İmza	Tarih
İsim	

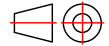
Değişiklik Revision	Tarih Date	Açıklama Explanation	GENEL İŞLEME TOLERANSLARI WORKING GENERAL TOLERANCES	GENEL PROFİL TOLERANSLARI PROFILE GENERAL TOLERANCES
			Doğrusal / Linears	Radius / Radius
			Açısal / Angulars	Açısal / Angulars
			Yüzey / Finishing	Yüzey / Finishing
			VERİLMEYEN RADYÜSLER RADIUS NOT QUOTED :	Dimensional fabrication tolerances: +/-10%
MALZEME - Material	AĞIRLIK / Weight	KABA ÖLÇÜ-Rough Size	ADET - Quantity	
ÇİZEN / Drawn by	K.DINLER			
KONTROL / Check.				
ONAY / Appr.				
ÖLÇEK / Scale	GRUP ADI - DESCRIPTION		DEĞ. YAPAN/Change by	TARİH / Date
			<b>Perforated flat bar,</b>  <b>GE-SL</b>	

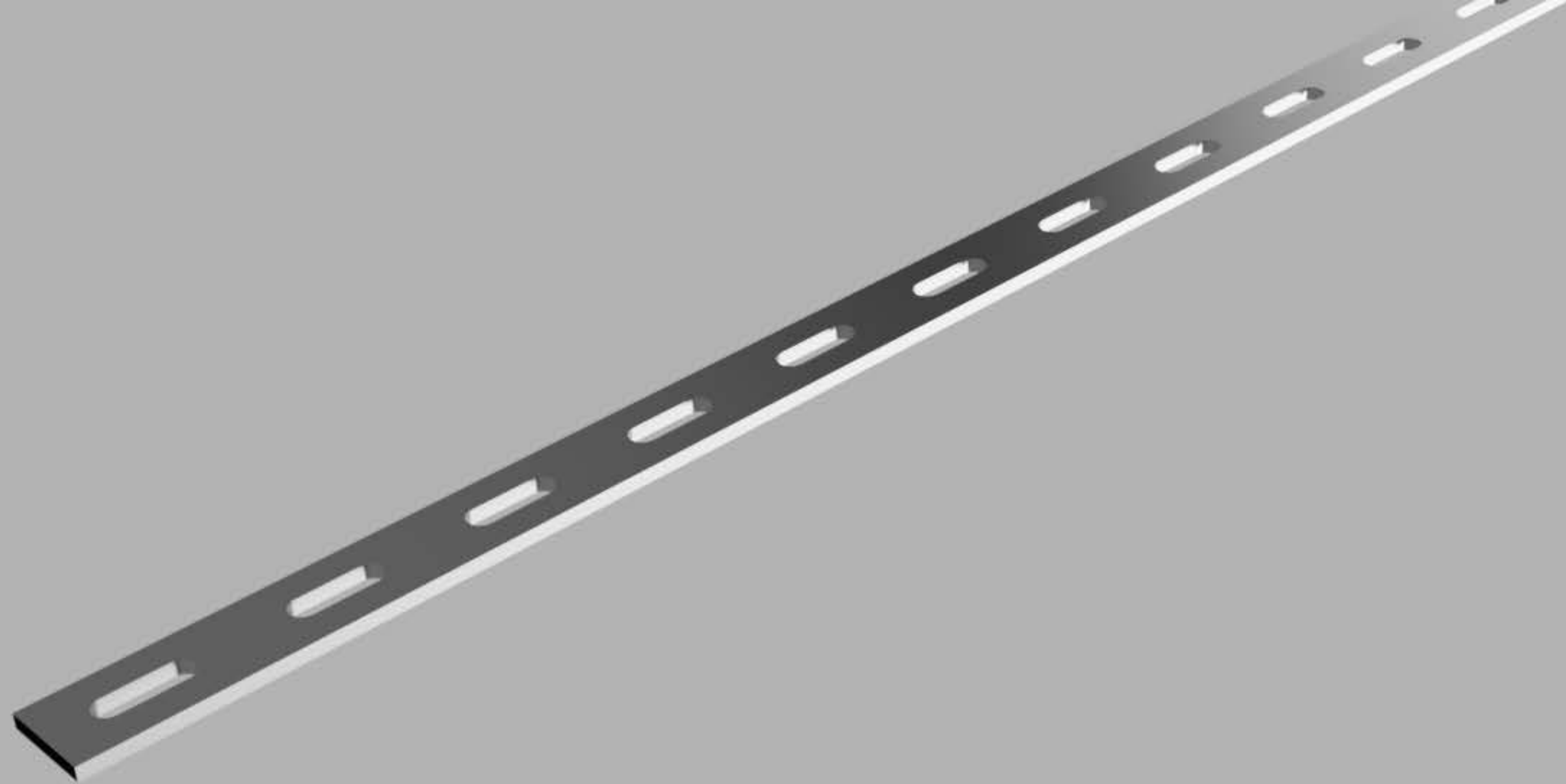

Dağıtım	Kop.
Tarih	
İmza	
İsim	
MALZEME	
İmza	
Tarih	
Kop.	
İmza	
Tarih	
Kop.	

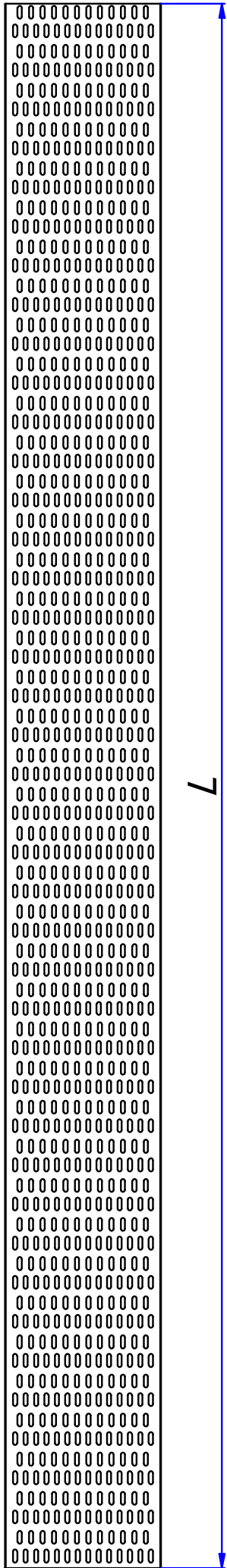

PART NO	T	W	A	L	-
GE-KTG-5-A15-1-L2	1	50	15	2000	
GE-KTG-7.5-A15-1-L2	1	75	15	2000	
GE-KTG-10-A15	1	100	15	2000	
GE-KTG-15-A15	1	150	15	2000	
GE-KTG-20-A15	1	200	15	2000	
GE-KTG-30-A15-1-L2	1	300	15	2000	

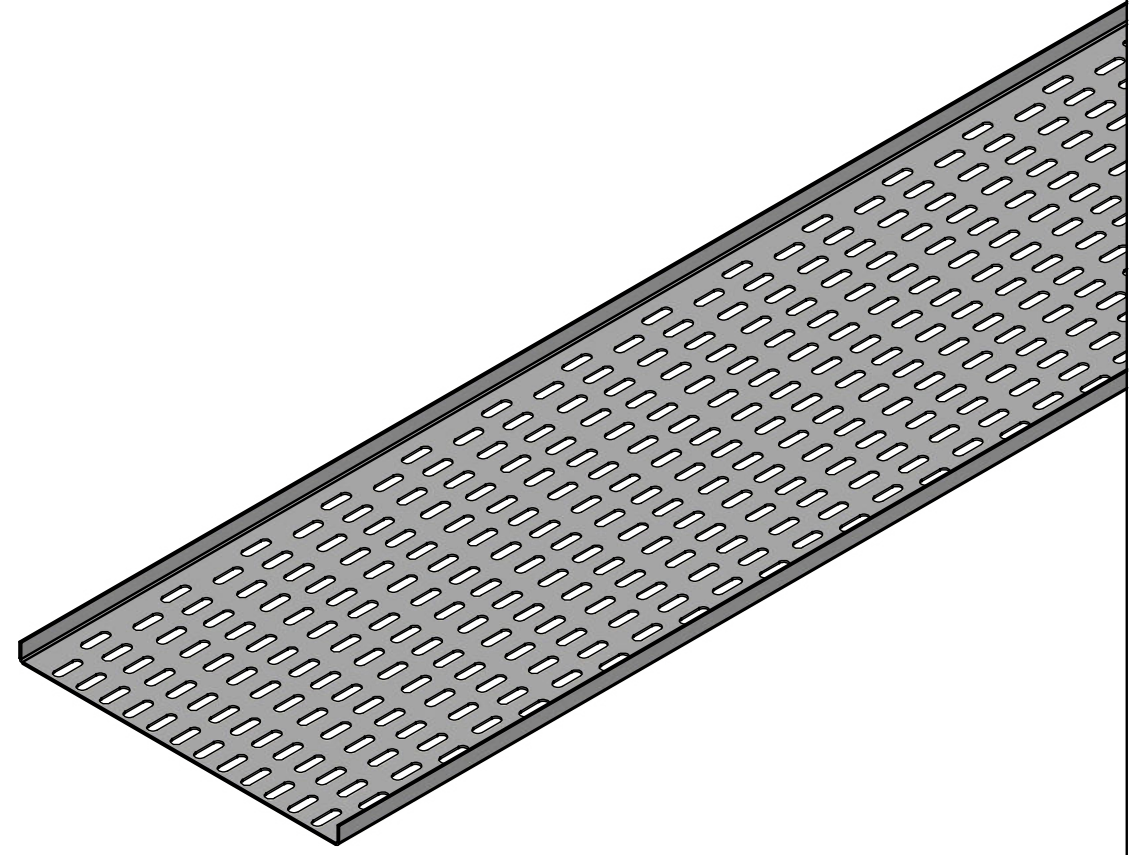
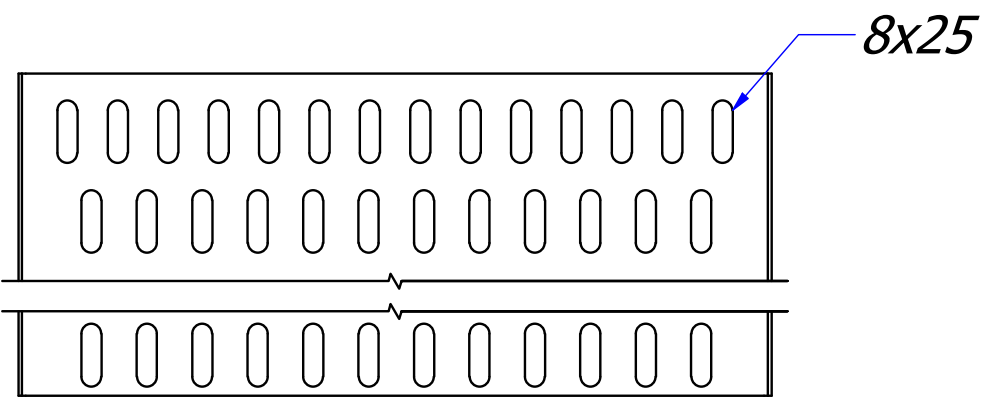
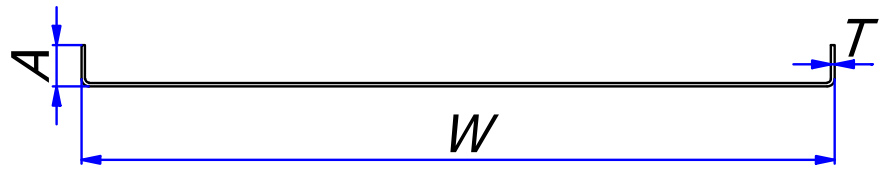

Değişiklik Revision	Tarih Date	Açıklama Explanation	GENEL İŞLEME TOLERANSLARI WORKING GENERAL TOLERANCES		GENEL PROFİL TOLERANSLARI PROFILE GENERAL TOLERANCES		
			Doğrusal / Linears		Yüzey / Finishing	✓ [✓]	Radyus / Radius
MALZEME - Material			AĞIRLIK / Weight	KABA ÖLÇÜ-Rough Size	ADET - Quantity	VERİLMEYEN RADYÜSLER RADIUS NOT QUOTED :	
ÇİZEN / Drawn by			K.DINLER				
KONTROL / Check.							
ONAY / Appr.							
ÖLÇEK / Scale			GRUP ADI - DESCRIPTION			DEĞ. YAPAN/Change by	TARİH / Date
			Marina Type Cable Tray			GE-KTG	

Dağıtım  
Kop.  
Tarih  
İmza  
İsim  
TEBARK

Dağıtım  
Kop.  
Tarih  
İmza  
İsim  
MALAT

Dağıtım  
Kop.  
Tarih  
İmza  
İsim

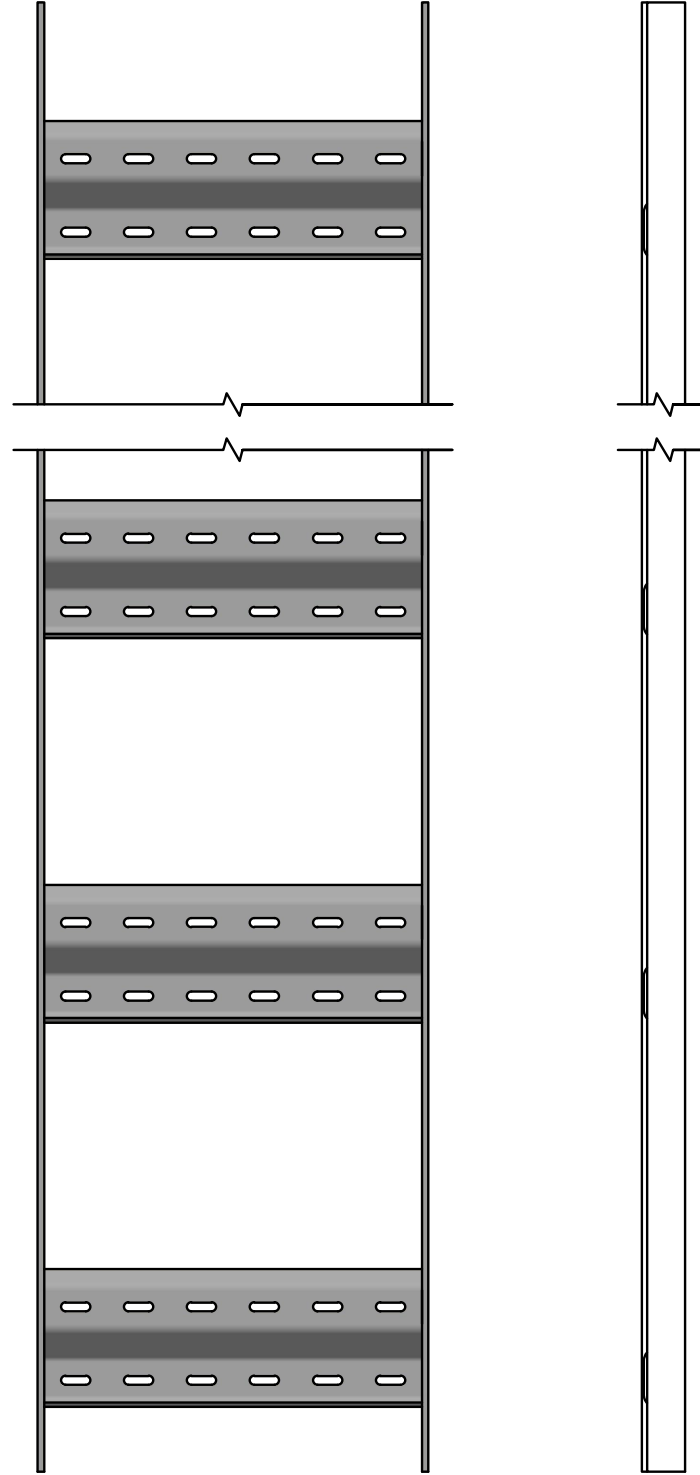
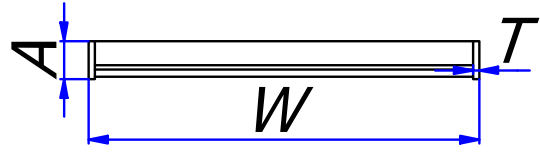

Rung section

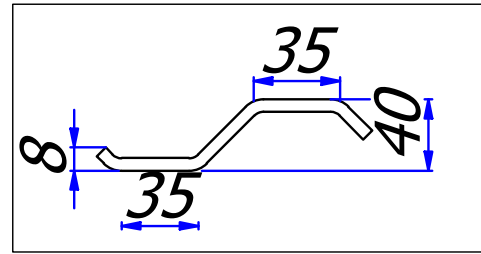

PART NO	T	W	A	L	-
GE-MG4-10-A40-L2	5	100	40	2000	
GE-MG4-15-A40-L2	5	150	40	2000	
GE-MG4-20-A40-L2	5	200	40	2000	
GE-MG4-25-A40-L2	5	250	40	2000	
GE-MG4-30-A40-L2	5	300	40	2000	

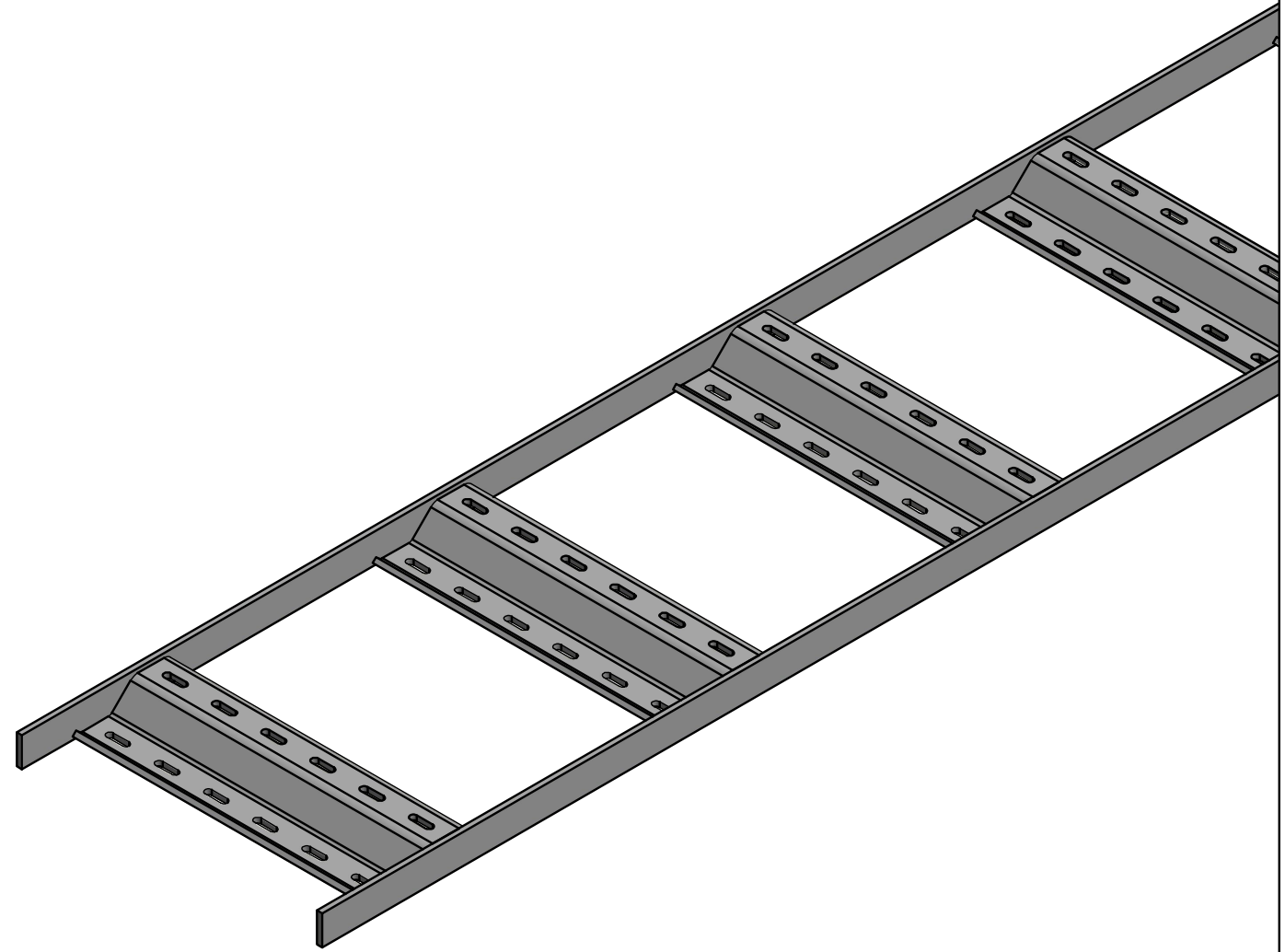

Değişiklik Revision	Tarih Date	Açıklama Explanation	GENEL İŞLEME TOLERANSLARI WORKING GENERAL TOLERANCES		GENEL PROFİL TOLERANSLARI PROFILE GENERAL TOLERANCES		
			Doğrusal / Linears	Açısal / Angulars	Yüzey / Finishing	Yüzey / Finishing	
MALZEME - Material			AĞIRLIK / Weight	KABA ÖLÇÜ-Rough Size	ADET - Quantity	Yüzey / Finishing	Yüzey / Finishing
						✓ [✓]	✓ [✓]
						VERİLMEYEN RADYÜSLER RADIUS NOT QUOTED :	Dimensional fabrication tolerances: +/-10%
ÇİZEN / Drawn by	K.DINLER		<b>ELNOVIS</b>				
KONTROL / Check.							
ONAY / Appr.							
ÖLÇEK / Scale	GRUP ADI - DESCRIPTION			DEĞ. YAPAN/Change by	TARİH / Date		
	Cable ladder with Z rung			GE-MG4			